

INSTRUCTION MANUAL

ENGLISH

ECLIPSE 100 ECLIPSE 35

WARNING: read the instructions carefully

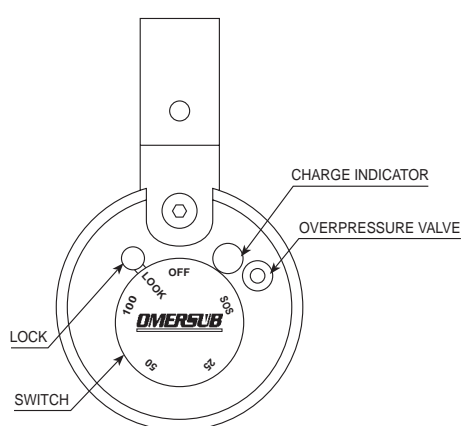

When the light uses 50% or 25% of available energy, all the display, safety, off and control functions match the functions of the light using 100% of available energy. All functions of the torch are always turned on gradually to prevent damages and its components more durable.

SOS FUNCTION

The SOS function can be detected by automatic decoders (to be found on military, commercial and rescue ships, coastguard and customs helicopters etc.).

The duration of the lines, the points and the intervals between the letters and the words are conventional ones, in accordance with the Morse code.

In the SOS position the light blinks using 50% of available power. The SOS signal continues to blink until the batteries become completely flat.

When operating in the SOS mode, the electronic system designed to prevent the cells from being overdischarged is not activated, allowing to extend the duration of the signal, in emergency situations, as much as possible.

Specifications:	Eclipse 35	Eclipse 100
Body material	Aluminium anticorodal	Aluminium anticorodal
Reflector material	Aluminium	Aluminium
Glass	6 mm, tempered	6 mm, tempered
Weight in air	1580 g	1980 g
Weight in water	748 g	948 g
Length	268 mm	214 mm
Diameter	68 mm	68 mm
Backlighted switch	Magnetic, 5 positions	Magnetic, 5 positions
Power selector	100%, 50%, 25%	100%, 50%, 25%
Range indicator	LED, 3 colours: green, yellow, red	LED, 3 colours: green, yellow, red
Standard lamp	35W Xenophot 3200° K	100W Xenophot 3200° K
Beam	Intermediate	Intermediate
Batteries	Ni-MH 9.6V 4300 mAh	Ni-MH 14.4V mAh
S.o.s. Morse code	Yes	Yes
Max depth	100 m	100 m
Temperature sensor	Yes	Yes
Overpressure valve	Yes	Yes
Mechanical safety lock	Yes, in OFF position	Yes, in OFF position
Optional equipment	Medium and Soft reflectors	Medium and Soft reflectors

CHECKS BEFORE DIVING:

- Make sure the body is perfectly closed.
- Immediately after plunging, put the light under water, to make sure that no bubbles come out of it.

FLOODING:

In case of flooding, always open the light and immediately rinse the internal parts with fresh water; then dry with a cloth and air, being careful not to damage the electronic circuit. Remove any oxide from the metal parts and immediately recharge.

If plenty of water has been let into the light and has remained there for a long time, it is recommended that the protective plastic film is removed and the instructions followed.

OPERATING LIMITS:

- Maximum operating depth: 100 m.
- Because of high operating temperatures, all torches must be used exclusively under water.

REPLACING LAMP:

- Unscrew the light and pull the internal battery pack out.
- Pull out the lamp and put the new one in, avoiding touching it with your hands (use a cloth).
- Place everything back, making sure that the lamp is aligned with the reflector hole.
- Close tightly.

MAINTENANCE:

- Always carry the light in either a protective bag or its original plastic case.
- Avoid any impacts.
- Do not expose to sunlight for long periods.
- After each dive (sea, lake or pool) always rinse with fresh water and dry.
- Check the O-ring whenever the light is opened. Clean and lubricate it with silicone grease.
- It is recommended that the torch is inspected by an authorized Omersub centre on a yearly basis.

OPTIONAL EQUIPMENT:

- 10, 20 and 30 W / 6 V lamps G4 fitting
- 20, 35 and 50 W / 12 V lamps G6.35 fitting.

We at Omersub have developed this range of lights with the intent of achieving outstanding durability, top-notch light and remarkable reliability. The light of Omersub torches is enhanced by electronic microcontroller switching technology.

Its operating process is based on output voltage choking with PWM technology, in order to allow the light to use 100%, 50% or 25% of the available energy.

The core of this product is the electronic circuit, based on low-consumption CMOS-type SMT technology.

This electronic circuit and the new magnetic switch, prevent the power absorption typical of mechanical switches, thus resulting in enhanced durability and a brighter light beam.

In addition, as there is no through switch, it is more difficult for water to enter and cause floods.

The torch also features an overpressure valve set at 1 bar, to discharge gas which can be accidentally created by the battery pack.

The main body is made in anodized anticorodal aluminium; the reflector is made in aluminium, thus resulting in an outstanding light beam: highly concentrated in the middle, with a large round corona. The Xenophot lamps cast an extremely white beam at a colour temperature of 3200 °K.

Tempered glass (6 mm thick) has been used to prevent light distortion.

MAIN FEATURES:

POWER SELECTOR

The rear cap features a five-position switch (OFF, 100%, 50%, 25% and SOS) which controls 4 hall sensors through a magnet on a revolving pin. For each function, the magnet polarizes a certain sensor, thus allowing current to flow and the electronic system to be turned on. The system is insensitive to external interference.

The switch is back lighted when any of the four functions (100%, 50%, 25% or SOS) is active and it features a mechanical lock, in the OFF position, to prevent the switch from being turned on accidentally. The lock should be pressed for rotation to be activated.

The switch is not through trough type controlling the internal electronic system through the aluminium wall of the torch.

When the light uses 50% or 25% of available energy, light fades and the light takes longer to be turned on.

The battery pack range equals the nominal value when the light uses 100% of available energy; it is about twice the nominal value when it uses 50% of available energy and four times the nominal value when it uses 25% of available energy.

OVERDISCHARGE CONTROL

When the light turns on, the multicoloured LED indicating the battery range also turns on. It is green until 5 minutes before the batteries become completely flat; then it starts blinking yellow. About 2 minutes before the batteries become flat, the LED starts blinking red. During the last minute before the batteries become totally flat, the red light turns into a red fixed light.

When the light is turned off, to prevent reverse polarity and gas formation (<0.8 V/cell), the LED is kept on (it is turned off if the switch is brought to the OFF position). The light can be turned on again, provided the battery pack is recharged (whether fully or partially) and the switch is brought back to the OFF position.

TEMPERATURE CONTROL

The light is provided with a thermistor for controlling the temperature of the battery pack. When the cell temperature exceeds 85 °C, the light is turned off. It can be turned on again provided the temperature falls below 50 °C and the switch is brought to the OFF position.

CHARGE CONTROL

While recharging the battery – whether the switch is in the OFF position or not –, a safety lock causes the light to be turned off, while preventing it from being turned on. The light can be turned on again provided the recharge coaxial socket is removed and the switch is brought back to the OFF position. This feature (either electronic or mechanical) is designed to prevent the battery charger from becoming overheated and the light from being accidentally turned on.

SPECIFICATIONS

- Numerically controlled body and metal parts made from anodized anticorodal aluminium.
- Rechargeable nickel-metal hydrate (Ni-Mh) battery pack.
- Concentrated beam spot reflector.
- Interchangeable Medium and Soft reflectors.
- Shaped aluminium handle with hole designed for lace.
- Rotating magnetic switch, five positions (OFF, 100, 50, 25, SOS).
- Xenon halogen lamp.
- Mechanical lock for preventing accidental switching in OFF position.
- Explosion-proof valve set at 1 bar.
- Multifunctional electronic circuit: prevents batteries from being over discharged and light from being turned on when recharge jack is plugged in.
- Plastic internal safety cursor to prevent light from being turned on.

WARNINGS

- Remove the light and fit the internal plastic cursor into the recharge socket (position B) if it is not used for long periods or while handling; when using the light or recharging the battery place the plastic jack back in the housing (position A).

Posizione A = Position A Posizione B = Position B

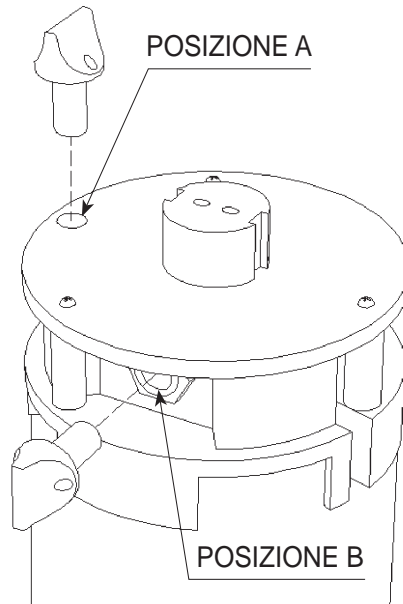

- Position OFF means the light is in the stand-by position; however, the electronic circuit is supplied with power (the blue LED of the switch blinks every three seconds); this means the batteries may become flat within about two or three weeks. To fully turn the light off, fit the plastic jack into the recharge socket (position B); the LED is off and the batteries do not supply any power.
- Do not turn the light on out of water.
- Do not unscrew the head or the base of the light while diving or if wet.

WARRANTY

All of Omersub's products are covered by warranties guaranteeing Omersub's responsibility for any material or manufacturing defects over a period of two years as from the purchasing date.

PRODUCT:

SERIAL NUMBER:

SHOP NAME:

SEAL:

DATE OF PURCHASE:

NAME:

ADDRESS:

CITY:

NB: This warranty shall not cover any damage resulting from the following:

- Misuse.
- Prolonged use or repairs carried out by unauthorized personnel.
- Prolonged use in chlorinated water.
- Use in polluted water.
- Use in any liquids other than water.
- Prolonged exposure to high temperatures or sunlight.

Omersub shall not be liable for any damage to the user caused by misused equipment, or for any immediate or consequential damage to people or things caused by failure to use the product for some time.